

Test: (2020) Primary 5 Science (Term 4) - ACS

Points: 56 points

Name: _____

Score: _____

Date: _____

Signature: _____

Select multiple choice answers with a cross or tick:

- Only select one answer
- Can select multiple answers

Question 1 of 63

Primary 5 Science (Term 4) 2 pts

For each question, four options are given. One of them is the correct answer.

James describe an organism to Lucy

- It needs oxygen
- It makes its own food
- It reproduces by spores
- It gives out carbon dioxide

Which of the following is the organism most likely to be?

-
- A)** Fern
- B)** Grass
- C)** Bacteria
- D)** Mushroom

Question 2 of 63

Primary 5 Science (Term 4)

2 pts

Five bar magnets with their ends marked A to J can be arranged as shown.

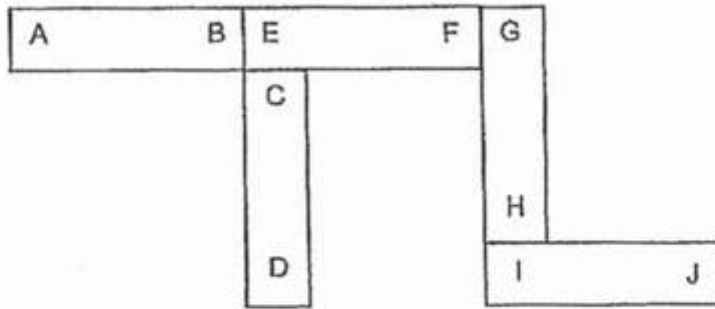

Which pair of poles will likely attract each other?

- A) A and G
- B) B and F
- C) C and I
- D) D and E

Question 3 of 63

Primary 5 Science (Term 4)

2 pts

The set-up shows light shining on three shapes, A, B and C, made of wood. They are hung from the ceiling and placed at different distances from the torch.

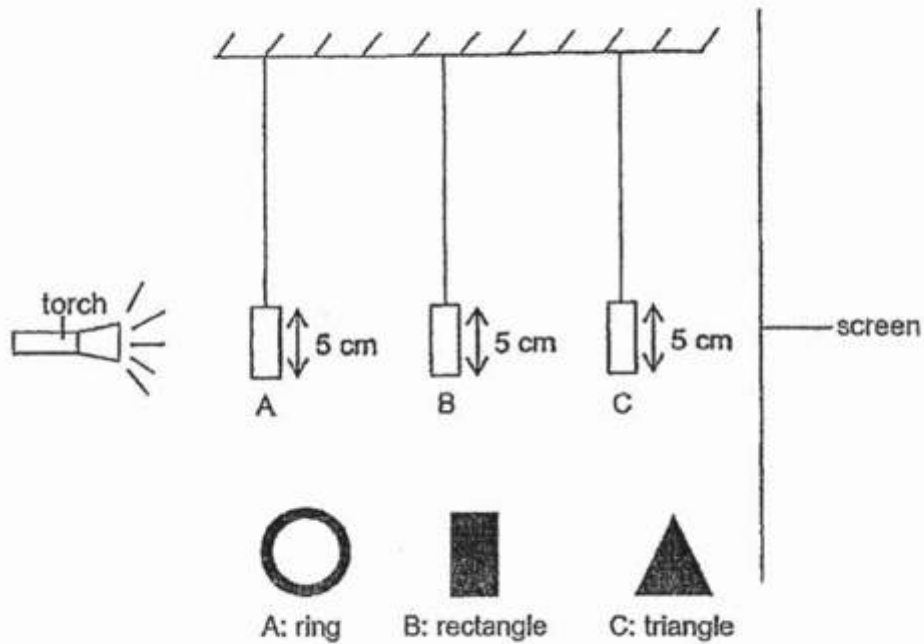

Which of the diagrams shows the shadow that was seen on the screen?

 A)

 B)

 C)



D)



Question 4 of 63

Primary 5 Science (Term 4)

2 pts

Study the flow chart carefully.

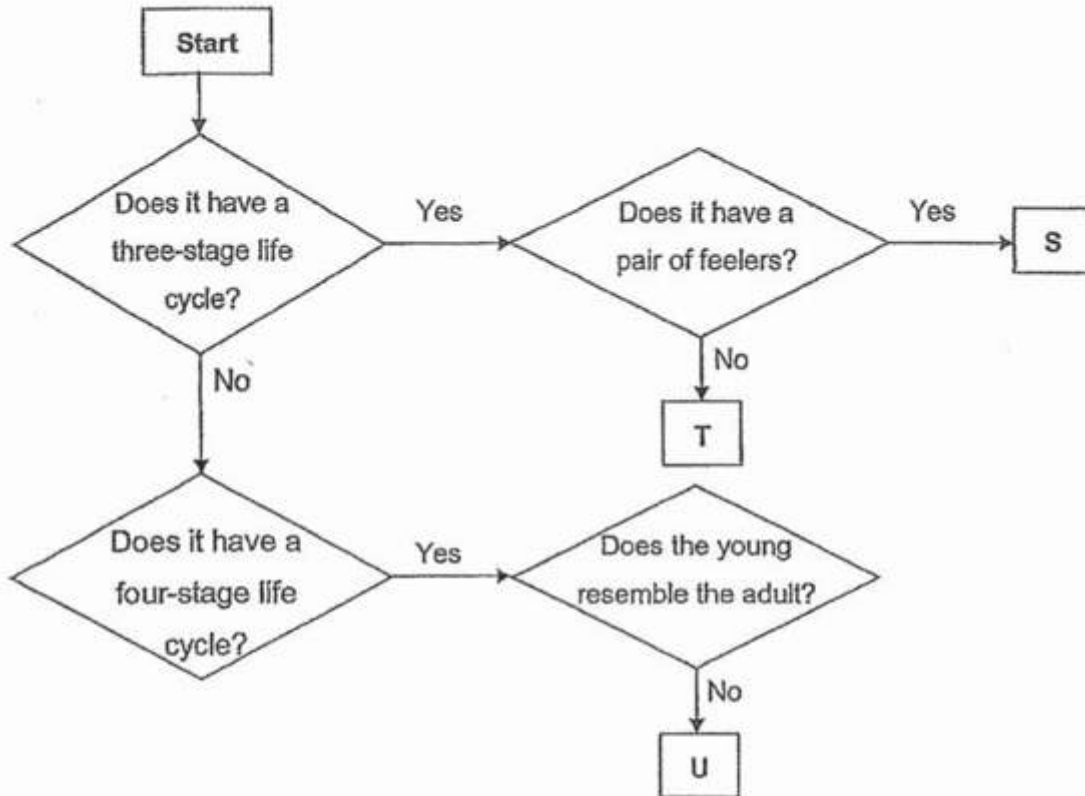

Which of the following animals can be represented by S, T and U?

| | S | T | U |
|-----|-------------|-----------|----------|
| (1) | cockroach | chicken | mosquito |
| (2) | chicken | cockroach | mealworm |
| (3) | grasshopper | rabbit | frog |
| (4) | mosquito | cockroach | rabbit |

- A) 1
 B) 2
 C) 3
 D) 4

Question 5 of 63

Primary 5 Science (Term 4)

2 pts

Study the diagram carefully.

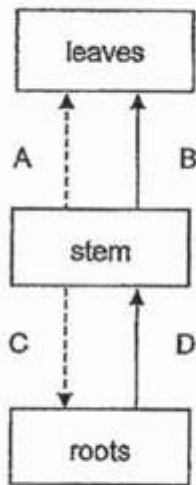

Key:

————→ Direction of water being transported.

-----→ Direction of food being transported.

Which arrow wrongly shows the direction of the substance being transported in a plant?

- A) A
- B) B
- C) C
- D) D

Question 6 of 63

Primary 5 Science (Term 4)

2 pts

William set up an experiment using a plant with white flower as shown in the diagram. He split the stem of the plant into halves and put one half in red-coloured water while the other half in blue-coloured water.

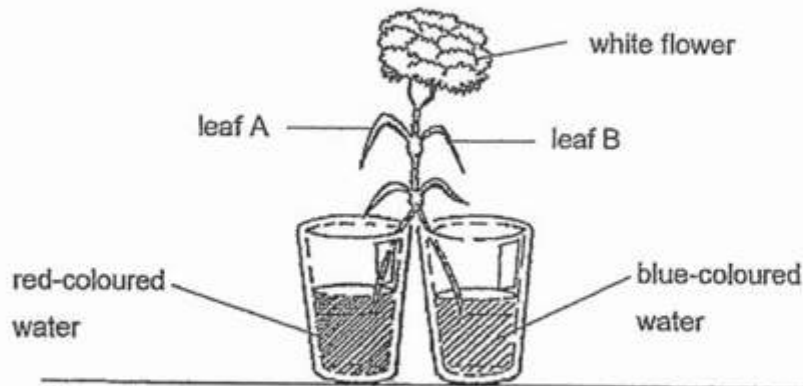

After some time, William observed that leaf A, leaf B and the white flower were stained. Which of the following most likely shows how the parts of the plant were stained?

| | Leaf A | Leaf B | White flower |
|-----|--|--|--|
| (1) | half-stained red and half-stained blue | half-stained red and half-stained blue | stained purple |
| (2) | stained blue | stained red | half-stained red and half-stained blue |
| (3) | stained red | stained blue | stained purple |
| (4) | stained red | stained blue | half-stained red and half-stained blue |

- A) 1
 B) 2
 C) 3
 D) 4

Question 7 of 63

Primary 5 Science (Term 4)

2 pts

Look at the diagram of a model of the human respiratory system.

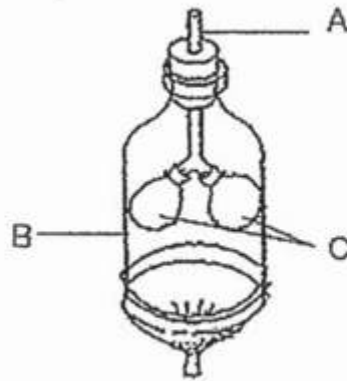

What do parts A, B and C represent in the human respiratory system?

| | A | B | C |
|-----|----------|----------|-------|
| (1) | chest | windpipe | lungs |
| (2) | lungs | windpipe | chest |
| (3) | windpipe | chest | lungs |
| (4) | windpipe | lungs | chest |

- A) 1
 B) 2
 C) 3
 D) 4

Question 8 of 63

Primary 5 Science (Term 4)

2 pts

The pie chart shows the composition of air.

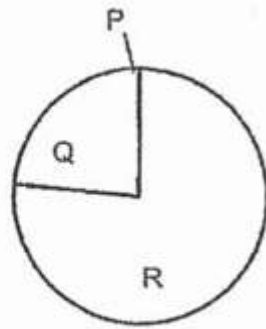

Match parts P, Q and R to the correct gases in air.

| | P | Q | R |
|-----|--|----------|--|
| (1) | nitrogen | oxygen | carbon dioxide |
| (2) | oxygen | nitrogen | carbon dioxide, water vapour and other gases |
| (3) | carbon dioxide and water vapour | nitrogen | oxygen |
| (4) | carbon dioxide, water vapour and other gases | oxygen | nitrogen |

- A) 1
 B) 2
 C) 3
 D) 4

Question 9 of 63

Primary 5 Science (Term 4) 2 pts

Which of the following graphs shows the breathing rate of a boy over a period of time when he rested at the beginning, then sprinted for a short distance and finally rested again?

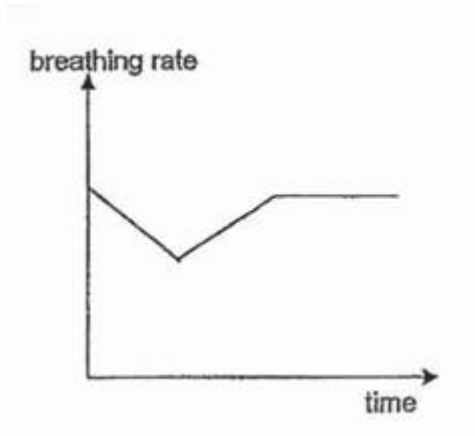
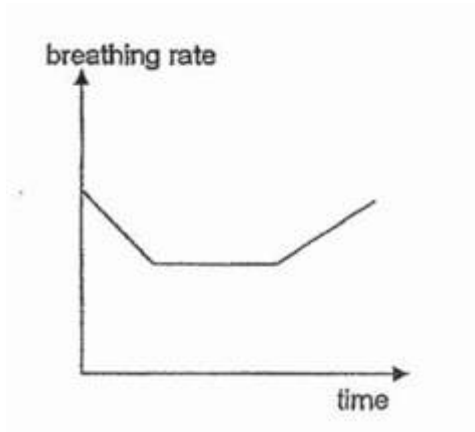
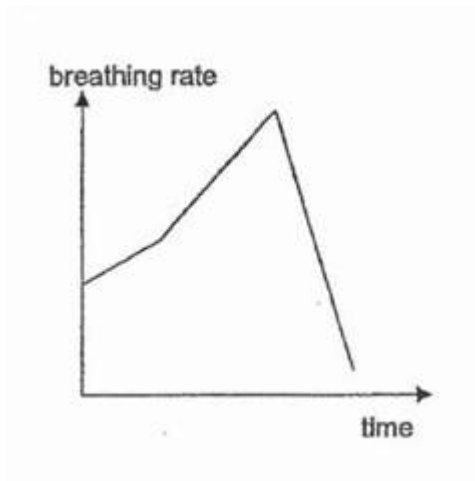
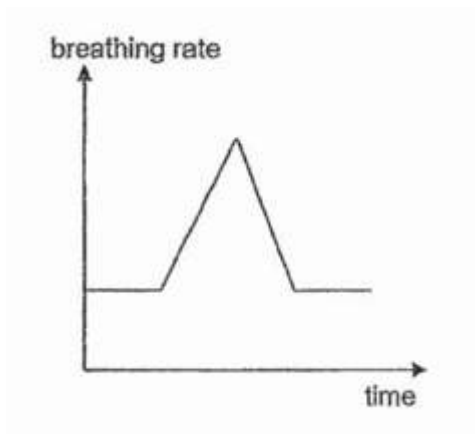
 A) B) C) D)

Question 10 of 63

Primary 5 Science (Term 4)

2 pts

In the diagrams shown, the arrows represent the flow of blood in two different systems.

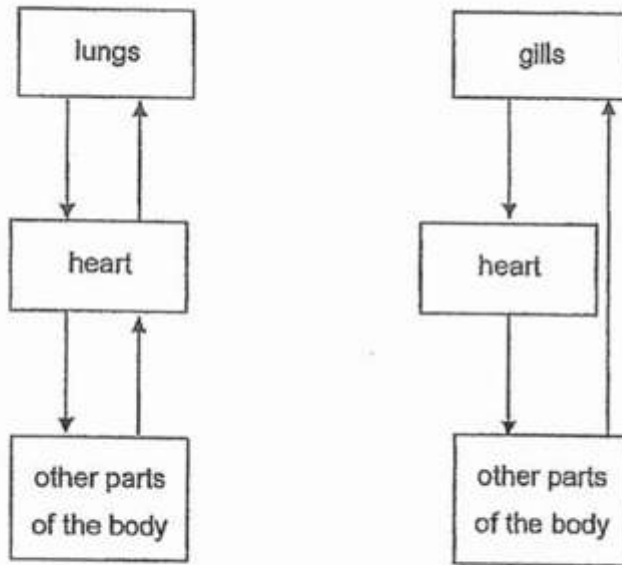

Which of the following statements is most likely true about the systems?

- A) The lungs and gills pump blood to the other parts of the body
- B) The lungs receive blood rich in carbon dioxide from the heart
- C) The gills receive blood rich in oxygen from the other parts of the body
- D) Both hearts receive blood rich in oxygen from the other parts of the body

Question 11 of 63

Primary 5 Science (Term 4)

2 pts

Peter has a toy car as shown in the diagram. There are two bulbs, four switches, a fan and a buzzer fixed to the toy car. All the components are in working condition.

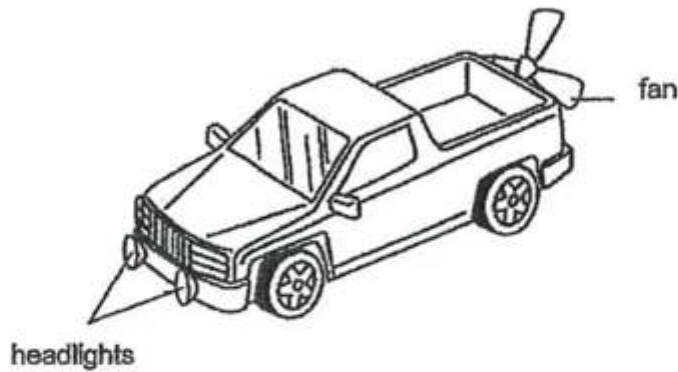

The circuit shows the arrangement of the components in the toy car.

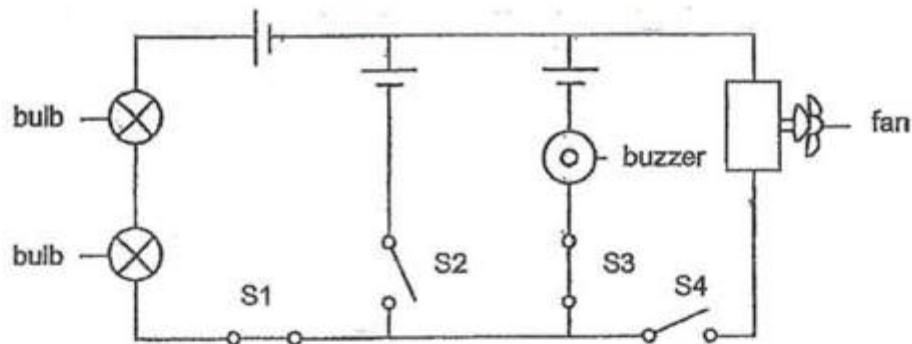

If Peter closes switches S1 and S3 and opens switches S2 and S4, which of the following will he observe?

| | Bulbs | Buzzer | Fan |
|-----|-----------------|---------------------|---------------|
| (1) | light up | makes sounds | does not spin |
| (2) | light up | does not make sound | spin |
| (3) | light up | makes sounds | spin |
| (4) | do not light up | makes sounds | does not spin |

- A) 1
 B) 2
 C) 3
 D) 4

Question 12 of 63

Primary 5 Science (Term 4)

2 pts

Study the diagram carefully.

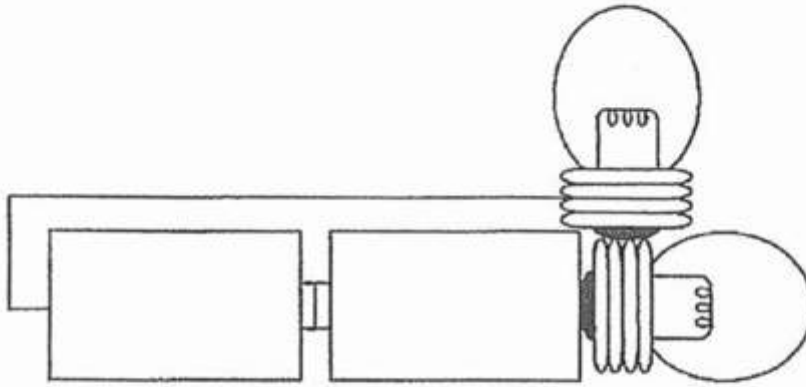

The batteries and light bulbs in the circuit shown are in working condition. However, the light bulbs did not light up.

Which of the following statements is a possible explanation for the above observation?

- A) The bulbs were arranged wrongly
- B) The batteries were arranged wrongly
- C) There was no switch to close the circuit
- D) The number of wires used was not enough

Question 13 of 63

Primary 5 Science (Term 4)

2 pts

The diagram shows three circuits with different arrangements of identical batteries and identical bulbs. The batteries and bulbs are in working condition.

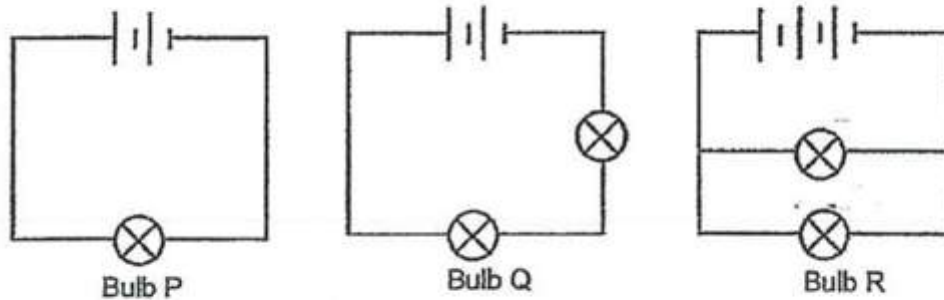

Which of the following shows the correct order of the brightness of the bulbs, starting with the brightest bulb?

- A) P,Q,R
- B) P,R,Q
- C) Q,R,P
- D) R,P,Q

Question 14 of 63

Primary 5 Science (Term 4)

2 pts

Which of the following are ways to conserve electricity?

- A Switch to energy saving light bulbs
- B Ensure the tap is turned off when brushing teeth
- C Turn off electrical appliances when not in use
- D Use the air conditioner instead of the fan on a cool day

- A) A and B only
- B) A and C only
- C) B, D and C only
- D) B, A and C only

Question 15 of 63

Primary 5 Science (Term 4)

2 pts

The picture shows many plugs inserted into a main socket.

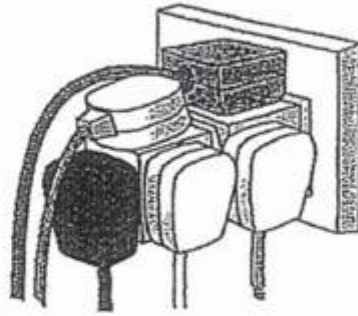

Which of the following best explains why we should not have too many plugs inserted into a main socket?

-
- A) The circuit may overload and may result in a fire
 - B) The plugs will drop off easily from the main socket
 - C) There may not be enough electricity for the rest of the house
 - D) The appliances will not work well as they will have to share electricity

Question 16 of 63

Primary 5 Science (Term 4)

2 pts

Tom wanted to investigate whether four rods, P, Q, R and S, were electrical conductors or insulators. He set up the circuit as shown.

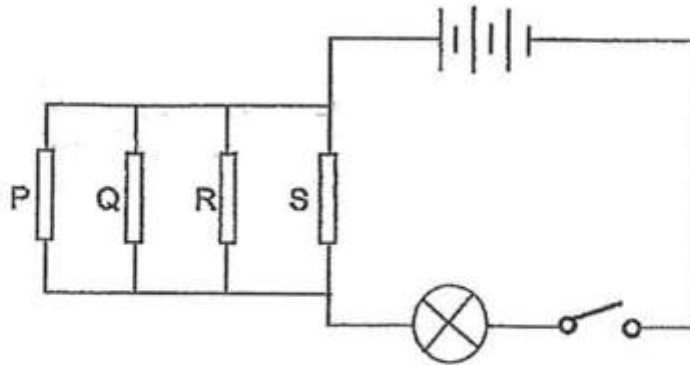

The table shows what happened to the bulb when the switch was closed and certain rod(s) was/were removed.

| Rod(s) <u>removed</u> from the circuit | Did the bulb light up? |
|--|------------------------|
| P | Yes |
| Q and R | Yes |
| P and Q | No |
| P, R and S | Yes |

Which of the following correctly represents the four rods P, Q, R and S?

| | P | Q | R | S |
|-----|-----------|-----------|-----------|-----------|
| (1) | conductor | insulator | conductor | insulator |
| (2) | insulator | insulator | conductor | conductor |
| (3) | conductor | conductor | insulator | insulator |
| (4) | insulator | conductor | insulator | conductor |

- A) 1
 B) 2
 C) 3
 D) 4

Question 17 of 63

Primary 5 Science (Term 4)

2 pts

Alvin prepared a set-up as shown in the diagram.

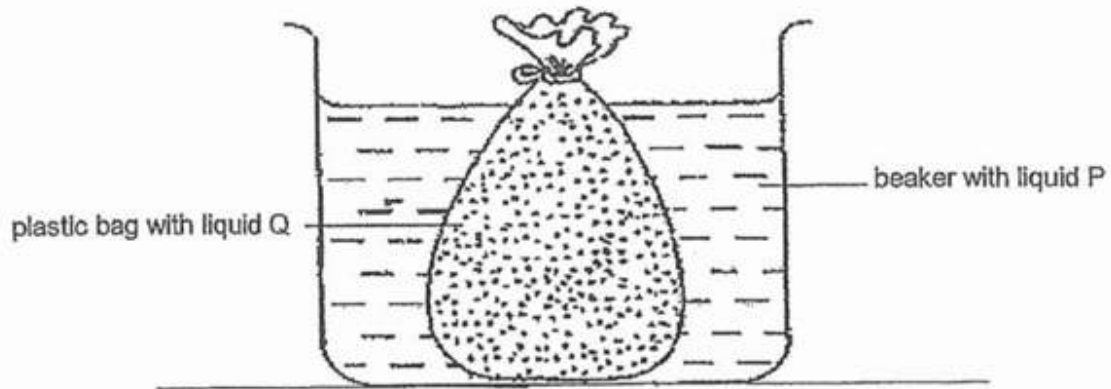

He placed a tightly sealed plastic bag containing liquid Q into a beaker containing liquid P.

After 5 minutes, he observed that some liquid P was found in the plastic bag.

Based on his observation, which part of the plant cell has a similar function as the plastic bag shown above?

- A) cell wall
- B) cytoplasm
- C) chloroplast
- D) cell membrane

Question 18 of 63

Primary 5 Science (Term 4)

2 pts

The diagram shows different parts of a plant.

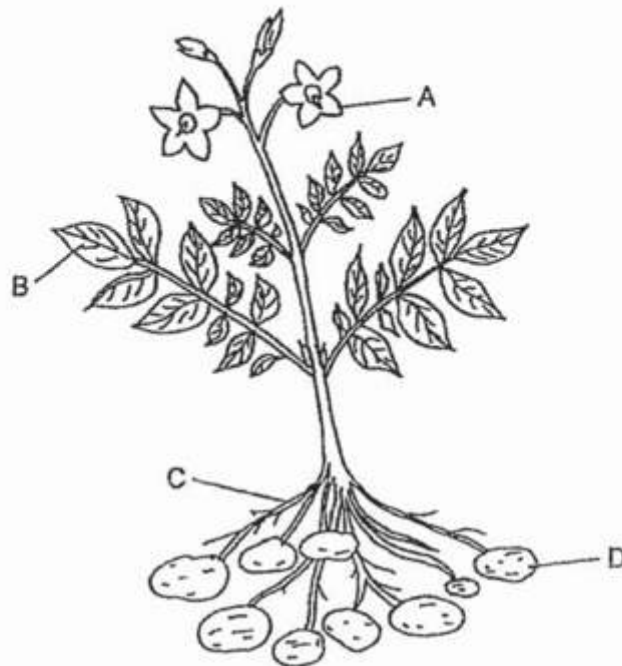

The diagram below shows a cell taken from one part of the plant above.

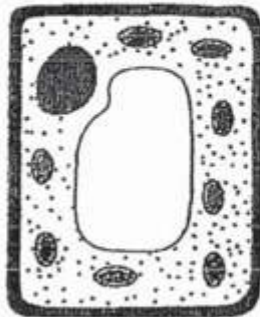

Which part of the plant is the cell most likely taken from?

- A) A
- B) B
- C) C
- D) D

Question 19 of 63

Primary 5 Science (Term 4)

2 pts

Four students observed three cells, A, B and C, and recorded their observations in the table shown.

| Cell Structure | Cell A | Cell B | Cell C |
|----------------|---------|---------|---------|
| Cell wall | Absent | Present | Present |
| Cytoplasm | Present | Present | Present |
| Chloroplast | Absent | Absent | Present |
| Cell membrane | Present | Present | Present |

They then made the following conclusions based on the information above.

| Student | Conclusion made |
|---------|---|
| Kaelan | Cell A can reproduce but Cells B and C cannot. |
| Shavin | Cell C can make food but Cells A and B cannot. |
| Calvin | Cells A and B are irregular in shape but Cell C is not. |
| Eu Jin | Cells B and C are plant cells but Cell A is an animal cell. |

Which of the students made correct conclusions?

- A) Kaelan and Shavin only
- B) Calvin and Eu Jin only
- C) Shavin and Eu Jin only
- D) Kaelan , Calvin and Shavin only

Question 20 of 63

Primary 5 Science (Term 4)

2 pts

Which of the following shows the correct sequence of processes in the reproduction of a flowering plant?

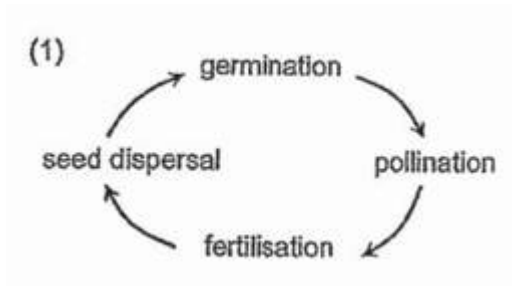
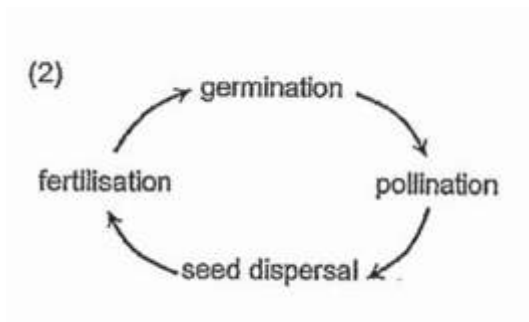
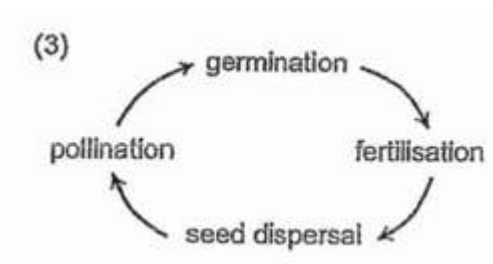
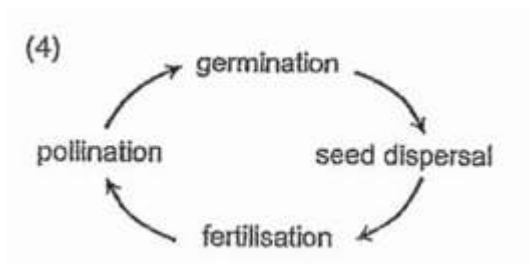
 A) B) C) D)

Question 21 of 63

Primary 5 Science (Term 4)

2 pts

Study the diagram of a flower carefully.

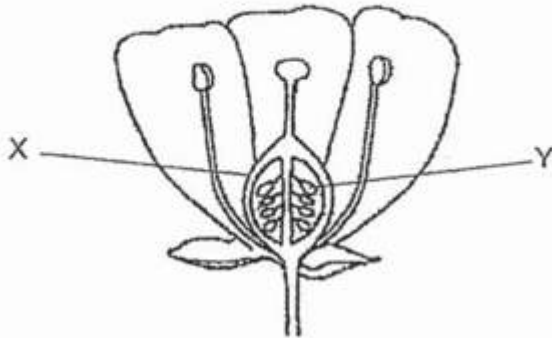

What would parts X and Y become after fertilisation?

| | X | Y |
|-----|-------|-----------|
| (1) | ovary | ovule |
| (2) | fruit | ovule |
| (3) | fruit | seed |
| (4) | ovary | seed leaf |

- A) 1
 B) 2
 C) 3
 D) 4

Question 22 of 63

Primary 5 Science (Term 4)

2 pts

The diagram shows an insect visiting a flower.



Which of the statements is most likely true about the flower?

- A) It has no pollen
- B) It has a strong scent
- C) Its stigma is not sticky
- D) Its petals are dull in colour

Question 23 of 63

Primary 5 Science (Term 4)

2 pts

Study the diagram carefully.

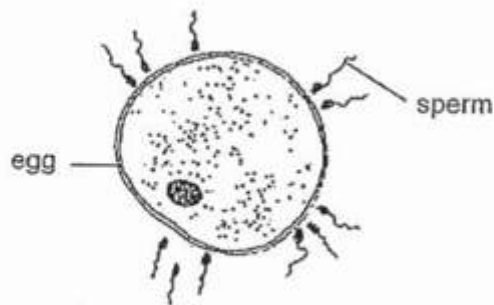

Which of the statements about fertilisation in humans is correct?

- A) Only one sperm fuses with the egg
- B) The egg has a cell wall that protects it
- C) Only the egg contains genetic information
- D) The egg will allow all the sperms to fuse with it

Question 24 of 63

Primary 5 Science (Term 4)

2 pts

Study the diagrams carefully.

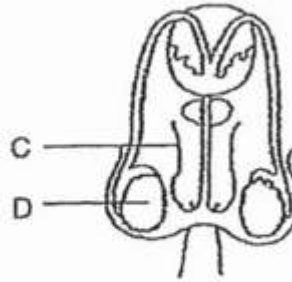
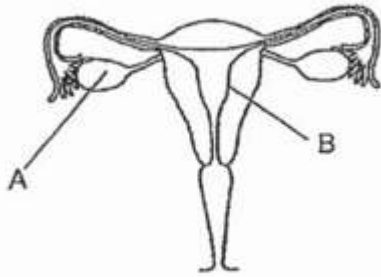

At which part does cell division take place after the egg is fertilised?

- A) A
- B) B
- C) C
- D) D

Question 25 of 63

Primary 5 Science (Term 4)

2 pts

Which of the following will not change as a person grows from a child into an adult?

- A: Height
- B: Fingerprint
- C: Colour of the eyes
- D: Ability to roll the tongue

- A) A and B only
- B) C and D only
- C) A, B and C only
- D) B, C and D only

Question 26 of 63

Primary 5 Science (Term 4)

2 pts

The diagram represents the water cycle.

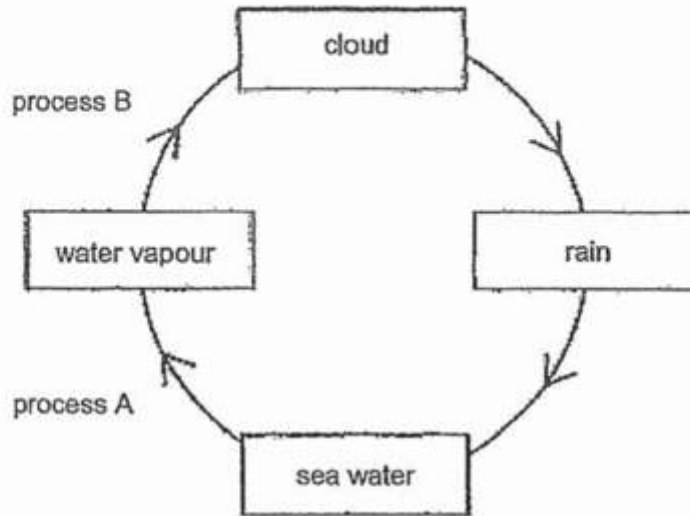

Which of the following correctly states whether heat is gained or lost during processes A and B?

| | process A | process B |
|-----|-----------------|-----------------|
| (1) | Heat is lost. | Heat is gained. |
| (2) | Heat is gained. | Heat is lost. |
| (3) | Heat is lost. | Heat is lost. |
| (4) | Heat is gained. | Heat is gained. |

- A) 1
 B) 2
 C) 3
 D) 4

Question 27 of 63

Primary 5 Science (Term 4)

2 pts

Which of the following activities helps us to conserve water?

- A) Not repairing a leaking pipe
 B) Soak in a bath tub instead of taking a quick shower
 C) Use the water from washing rice grains to water plants
 D) Let the water run from the tap while brushing our teeth

Question 28 of 63

Primary 5 Science (Term 4)

2 pts

The diagram represents the water cycle.

X, Y and Z are certain processes that must occur to ensure the continuity of the water cycle.

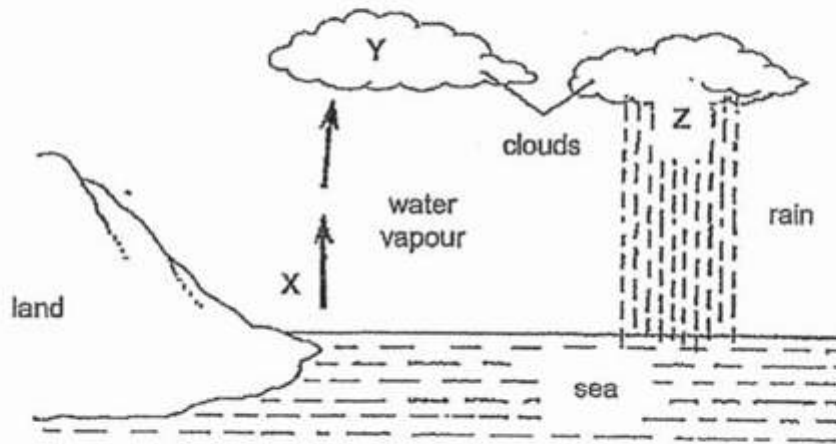

Which of the following statements about the water cycle is correct?

- A) X take place during the day only
- B) Z takes place when water droplets condenses
- C) Y takes place when water vapour evaporates
- D) Z returns water in the liquid state back to earth

Question 29 of 63

Primary 5 Science (Term 4)

0 pts

The diagram shows the human digestive system.

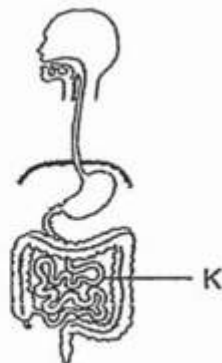

(a) What happens to the food after it is broken down into simpler substances in part K? [1]

Question 30 of 63

Primary 5 Science (Term 4) 0 pts

- (b) To study the function of the small intestine and large intestine, Ronald plotted bar graphs X and Y to show the amount of undigested food leaving each of the two parts.

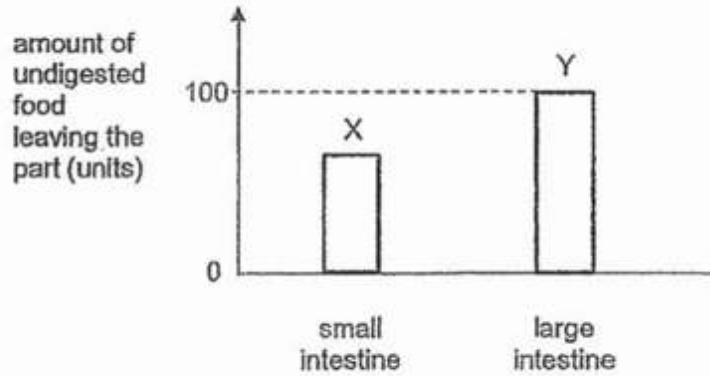

He plotted graph Y wrongly. Should bar graph Y be the 'same as' or 'lower than' bar graph X? Explain your answer. [1]

Question 31 of 63

Primary 5 Science (Term 4) 0 pts

Jim studied the life cycle of insect X. He recorded the number of days for each stage of its life cycle in the graph as shown. However, Jim did not present the stages of the life cycle in the correct order.

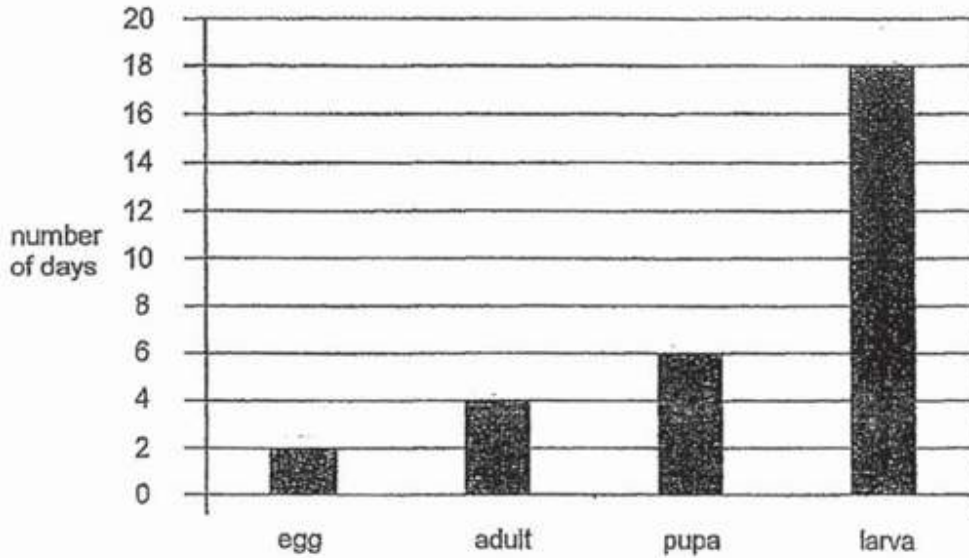

(a) Write down the stages of the life cycle of insect X in the correct order.

[1]

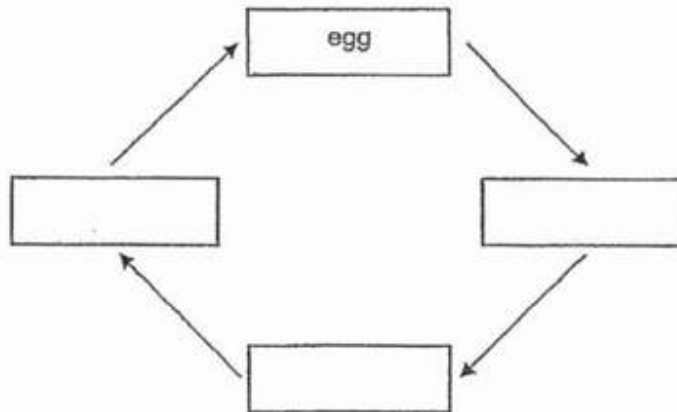

Question 32 of 63

Primary 5 Science (Term 4) 0 pts

b) Based on Jim's results, how many days does it take for insect X to become an adult after the egg has hatched?

Question 33 of 63

Primary 5 Science (Term 4) 0 pts

- (a) Draw a line to complete each statement about the amount of gases we exhale and inhale. [1]

| | | | |
|---|---|---|-----------------------------|
| When we exhale, the amount of nitrogen is | ● | ● | less than what we inhale. |
| When we exhale, the amount of oxygen is | ● | ● | more than what we inhale. |
| When we exhale, the amount of carbon dioxide is | ● | ● | the same as what we inhale. |

Question 34 of 63

Primary 5 Science (Term 4) 0 pts

- b) Describe the path that oxygen from the surrounding air takes to enter the blood in our body

Question 35 of 63

Primary 5 Science (Term 4) 0 pts

- c) State the part where the exchange of gases takes place in:

Human:

Leaves :

Question 36 of 63

Primary 5 Science (Term 4)

0 pts

Max observed a human cheek cell under a microscope.

- (a) Using a pencil, draw a cell that he would have observed in the box provided below.
In your drawing, label two cell parts, P and Q. [2]

P: a jelly-like substance where cell activities take place

Q: a cell part which controls all activities

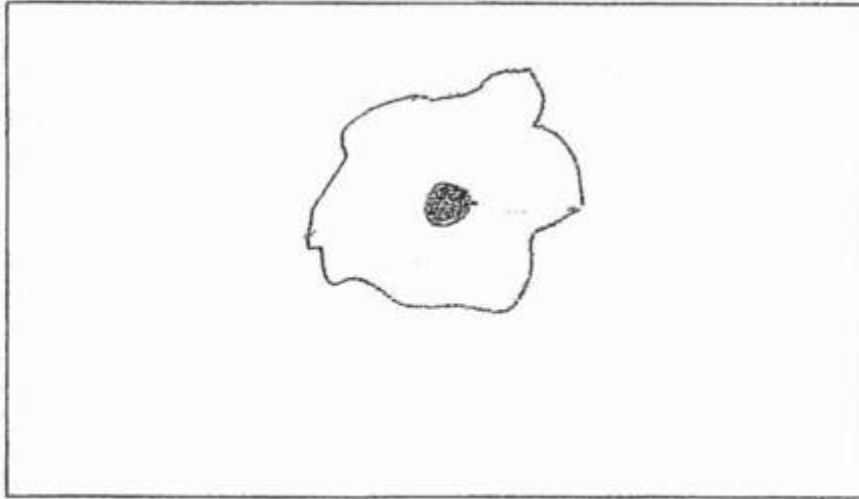

Question 37 of 63

Primary 5 Science (Term 4) 0 pts

Max then observed a single-celled microorganism Y found in pond water under a microscope. Microorganism Y has some parts that trap sunlight to make food during the day.



- (b) State one similarity and one difference between the human cheek cell and microorganism Y. [2]

Similarity:

Difference:

Question 38 of 63

Primary 5 Science (Term 4) 0 pts

- a) State why living things reproduce

Question 39 of 63

Primary 5 Science (Term 4) 0 pts

(b) Observe the diagrams carefully.



Ali



Ali's father



Ali's mother

Explain why the shape of Ali's thumb looks similar to his father's thumb but not his mother's. [1]

Question 40 of 63

Primary 5 Science (Term 4) 0 pts

c) Which reproductive part in both humans and females flowering plants has a similar function? Explain

Question 41 of 63

Primary 5 Science (Term 4) 0 pts

d) Explain why male human reproductive cells are produced in large numbers each time during sexual reproduction

Question 42 of 63

Primary 5 Science (Term 4)

0 pts

Louis carried out an experiment on two parts, X and Y, of two similar plants. He removed some fruits from part Y but not part X as shown. Both parts have the same number of leaves and were grown in the same location with the same conditions.

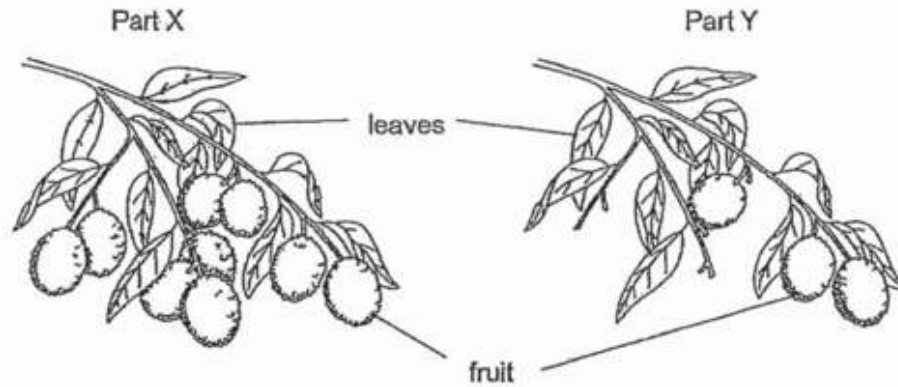

- (a) Explain how the remaining fruits on part Y grew bigger than those on part X after some time. [2]

Question 43 of 63

Primary 5 Science (Term 4)

0 pts

- b) Why did Louis choose plants from the same location for a fair test?

Question 44 of 63

Primary 5 Science (Term 4)

0 pts

- c) Describe the function of the water- carrying tubes in plants

Question 45 of 63

Primary 5 Science (Term 4)

0 pts

The diagrams show two fruits, A and B, with different methods of dispersal.

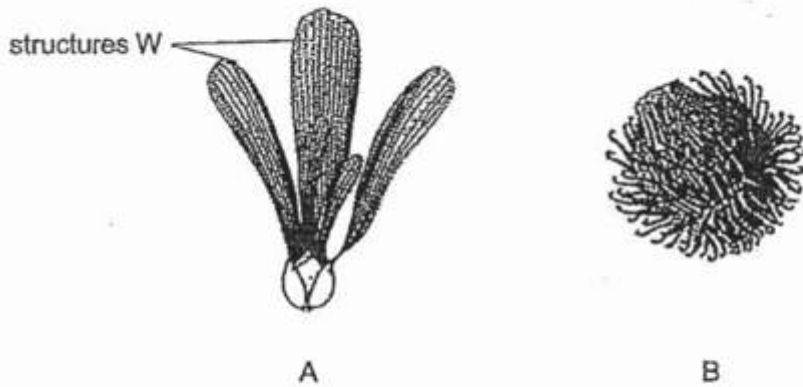

- (a) Based on the diagrams, which fruit, A or B, is more likely to be dispersed by animals?
Explain your answer. [2]

Question 46 of 63

Primary 5 Science (Term 4)

0 pts

- b) Structure W of fruit A were completely removed. How would this affect the distance travelled by fruit A from its parent plant during its dispersal?

Question 47 of 63

Primary 5 Science (Term 4)

0 pts

The diagram shows two similar plants growing side by side in a farm.

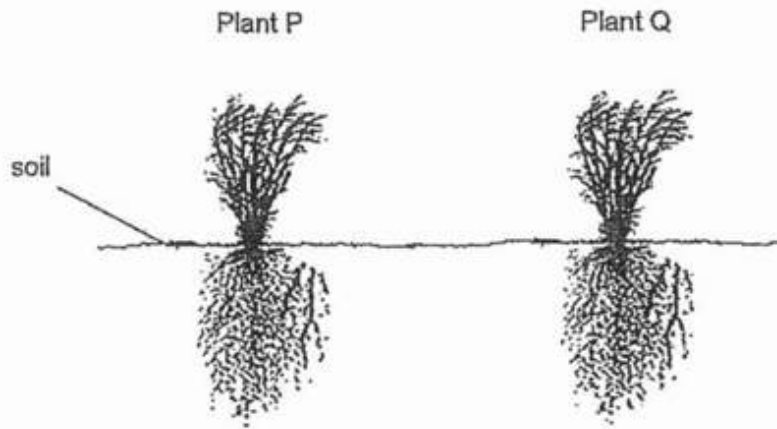

(c) (i) State two substances that both plants P and Q need from the soil to survive. [1]

_____ and _____

Question 48 of 63

Primary 5 Science (Term 4)

0 pts

cii. Explain the advantage of growing the two plants with a space in between them

Question 49 of 63

Primary 5 Science (Term 4) 0 pts

Alice cooked some soup in a pot and wanted to keep it as hot as possible.

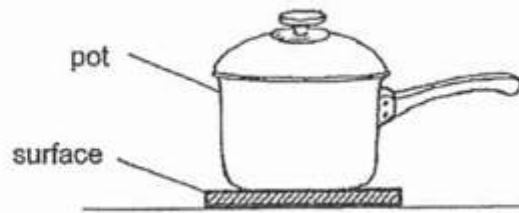

Should she place the pot on a metal or wooden surface? Explain your answer.

Question 50 of 63

Primary 5 Science (Term 4) 0 pts

Robert wanted to find out which glass, A, B, C or D, is most suitable to be used for his room window to prevent as much light as possible from entering. He placed a piece of glass in front of a torch and shone a light through it as shown. He conducted the experiment in a dark room.

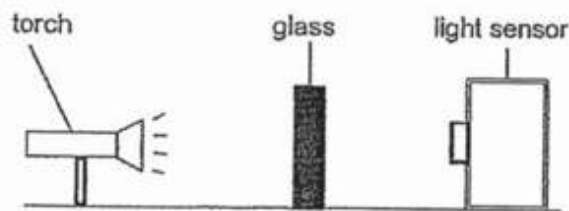

The amount of light that passed through the glass was measured and recorded in the table below. He repeated his experiment with different types of glasses but of identical size with the same torch and light sensor.

| Glass | Amount of light that passed through (units) |
|-------|---|
| A | 2000 |
| B | 1600 |
| C | 1200 |
| D | 1450 |

(a) Based only on the results, what is a conclusion that Robert can make?

[1]

Question 51 of 63

Primary 5 Science (Term 4) 0 pts

b) Suggest another variable to be kept constant

Question 52 of 63

Primary 5 Science (Term 4) 0 pts

Device A is used to move the toy car which has a steel bar on it.

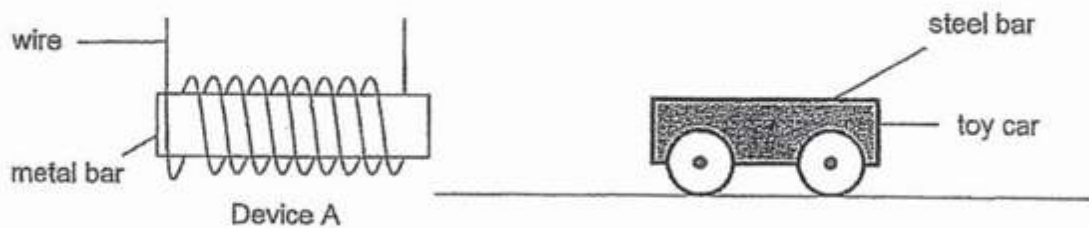

- (a) Using a pencil and ruler, draw electrical components to close the circuit in Device A below so that the toy car can move towards it. Use electrical symbols in your drawing.

[1]

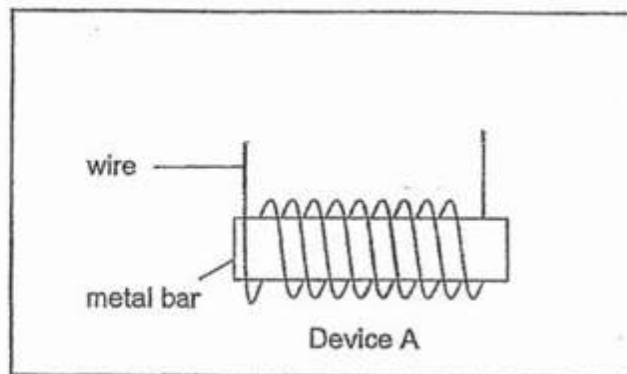
**Question 53 of 63**

Primary 5 Science (Term 4) 0 pts

b) What could be done to Device A so that the toy car can move faster?

Question 54 of 63

Primary 5 Science (Term 4)

0 pts

Roy designed an electrical system for a fan and an air conditioner as shown. The system prevents both the fan and air conditioner from being turned on at the same time.

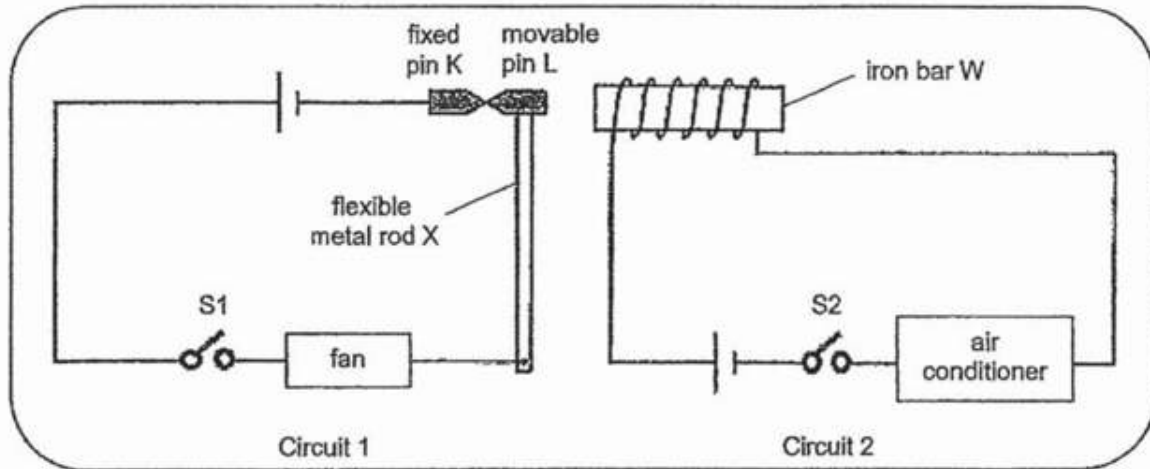

Iron bar W is placed inside a coil of wire. K and L are two iron pins in contact with each other. Pin K is fixed. Pin L is attached to a metal rod X which can move sideways. Roy closed switch S1 to turn the fan on. Next, he closed switch S2 which turned the air conditioner on.

- (a) Explain why Pin L would move towards iron bar W when switch S2 was closed. [1]

Question 55 of 63

Primary 5 Science (Term 4)

0 pts

- b) Give a reason why the fan would turn off when switch S2 was closed

Question 56 of 63

Primary 5 Science (Term 4)

0 pts

- c) Explain why Roy's electrical system would not work if Pin L was changed to copper

Question 57 of 63

Primary 5 Science (Term 4) 0 pts

The diagram represents an electrical circuit with four switches, A, B, C and D.

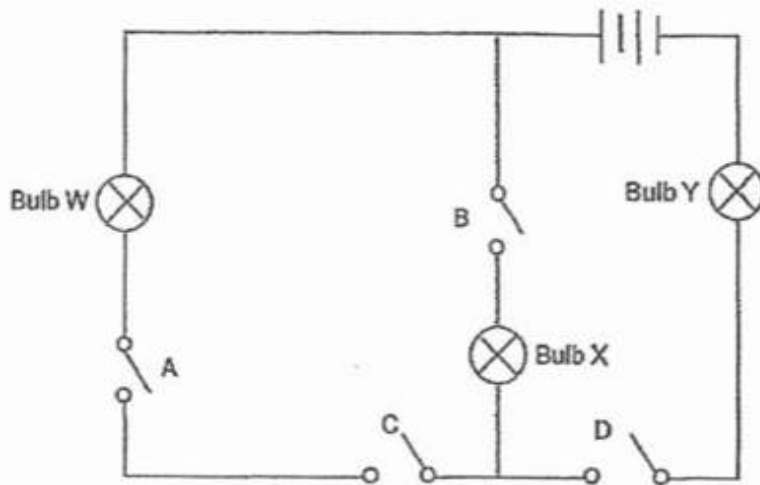

- (a) Which two switches must be closed for two bulbs to light up at the same time? [1]

Switches _____ and _____

Question 58 of 63

Primary 5 Science (Term 4) 0 pts

- b) When all the switches are closed and Bulb X fuses, explain why bulb Y can still light up.

Question 59 of 63

Primary 5 Science (Term 4) 0 pts

- c) State which two bulbs are arranged in parallel

Bulbs ___ and ___

Question 60 of 63

Primary 5 Science (Term 4) 0 pts

d) State one advantage of arranging bulbs in parallel

Question 61 of 63

Primary 5 Science (Term 4) 0 pts

The diagram shows a tightly sealed glass container with some 90°C blue-coloured water in it.

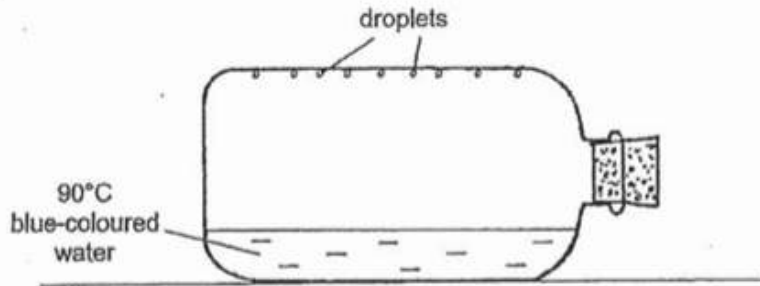

(a) Name the two processes that caused the droplets to form.

[1]

_____ and _____

Question 62 of 63

Primary 5 Science (Term 4) 0 pts

b) What is the color of the droplets formed?

Question 63 of 63

Primary 5 Science (Term 4) 0 pts

c) What would most likely happen to the amount of droplets if 50 degree celcius blue coloured water was used instead? Explain your answer
